

Cleaning Technology · Municipal Technology

Hako

Clean ahead



Multicar FUMO

Crew cabin

Powerful implement carrier & transport vehicle



Efficient and flexible – twice as good for you and your team

The Multicar FUMO with crew cabin seats up to five persons and is extremely flexible when it comes to implementing equipment technology. More than 100 different attachments are available to be connected to three attachment points for fast and easy modification and all-season employment. The made-to-last, low-maintenance Multicar FUMO crew-cabin model enables efficient, custom-tailored crew-employment. The ultimate achievement in economic efficiency.



Multicar FUMO C
with crew cabin,
4x4 all-wheel drive and
3-way tipper

Three attachment
points for individual
vehicle configuration

Independent suspension
with helical springs
at the front and
leaf springs at the rear

Climbing capacity on open
terrain with 4x4 all-wheel drive
up to 32 degrees up to 62%

Gross combination
weight rating up to 7.5 t

Excellent performance in every detail

The Multicar FUMO with crew cabin: Technology and freedom for everybody

High level of flexibility

Equipped with three attachment points and with over one hundred implement options, the Multicar FUMO with crew cabin is a highly functional, all-round talent. It can be converted for the next job with just a few manual operations. Combined with its narrow width of just 1.62 m, the Multicar FUMO can be deployed 365 days a year, in both summer and winter, on roads, in pedestrian precincts or on open terrain.

Excellent efficiency

Your faith in the Multicar FUMO will be repaid in several ways: Use of high quality materials, ensuring first class workmanship and applying high grade anticorrosive, for example, mean it has a particularly long service life. The high-performance, common-rail diesel engine means low fuel consumption and, therefore, reduces operating costs. Even with regard to maintenance and service, the Multicar FUMO shines through the low costs!

Always comfortable

The Multicar FUMO offers excellent driving and working qualities, the 5-seater concept allowing for a gang of workers to be transported to the job site. Four-wheel drive and the crawling gear can be engaged at the push of a button if required or the vehicle can be swiftly accelerated from 0 to 90 km/h or 110 km/h (class N1). The powerful attachments and mounted tools are precise and easy to operate.

Quality made in Germany

Multicar has been developed and produced in Germany for more than 50 years.



Gross combination weight rating max. 7.5 t, max. payload 2.9 t and braked trailer weight of max. 3.5 t



Balanced handling and secure roadholding whether in a loaded or unloaded state due to the independent suspension with helical springs at the front and progressive leaf springs with telescopic shock absorbers at the rear





Modern, ergonomically designed space-frame cab with unimpeded view of the working equipment and surrounding area as well as a crew cab for transporting up to five persons



High performance and economic:
Low-noise, 3-litre turbodiesel engine from IVECO producing 107 kW (145 hp). Complies with EURO 5 and EEV standard for use in all low emission zones

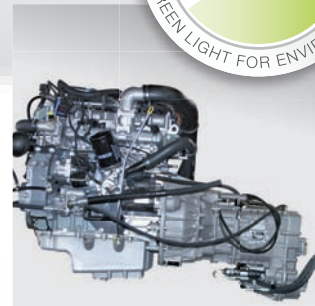

Three different attachment points and front quick-change system with raising and lowering function for the simple attachment of a wide range of implements



Attachments are driven by the vehicle's powerful hydraulics – and easily connected to non-drip, flat-sealed, quick-connecting couplings



1) Handles like a car

due to the optimally balanced vehicle configuration and 5-gear manual transmission

2) Full-size rear seating

increases the number of seats in the vehicle to five

3) 4x4 all-wheel drive

for optimal traction, the differential lock provides even more safety when at work

4) Power-assisted steering

with smooth, precise ball nut hydraulic steering for easy manoeuvring

5) Air-con unit

to enable concentrated, efficient and safe working in summer

6) Ergonomically designed comfort seats

can be adjusted forward and back, in height and with adjustable backrest





A glance at the ergonomically designed workplace

Functionality and ergonomics: The Multicar FUMO with crew cabin makes work easier

Both the advanced technology and functionality of the Multicar FUMO with crew cabin make work very easy for you. The sound-insulated and ergonomically designed space-frame cabin allows for plenty of elbow-room.

The big low-cut windows enable an excellent view of the working environment and the tools. All the control elements are clearly marked and within easy reach of the driver. The Multicar FUMO with crew cabin seats up to 5 persons, enabling efficient staff employment without making sacrifices to functionality or load capacity.

Functionality is continued in the exterior: Modern quick-change systems enable an uncomplicated change of attachments to modify the implement carrier in no time at all!



Tailor-made solutions for individual tasks

The Multicar Fumo with crew cabin – always a good choice

The Multicar FUMO's modern vehicle concept offers you plenty of possibilities. Choose just the right equipment for you to gain efficiency and save costs. The Multicar FUMO with crew cabin transports up to five workers directly to the job-site. The vehicle can be easily modified or upgraded. You can choose between a 4x2 or 4x4 all-wheel-drive transport vehicle and a 4x4 all-wheel-drive implement carrier, plus plenty of optional equipment.

Multicar FUMO
with crew cabin;
coachwork:
mobile elevated
work platform by
manufacturer
Blumenbecker



Multicar FUMO T crew cabin

- special transport vehicle with huge load capacity
- electro-hydraulically operated 3-way tipper
- very flexible in use due to a payload of 2.9 t, a permissible trailer weight of up to 3.5 t and a max. permissible weight of up to 5.6 t

Multicar FUMO C crew cabin

- Professional implement carrier with 3-circuit hydraulics
- Powerful hydraulics for driving several implements simultaneously and independently
- Operating up to three hydraulic circuits using the 3-circuit universal hydraulics (working pressure up to 200 bar)
- 3-circuit high pressure comfort hydraulics (working pressure up to 300 bar), the volume flow can be controlled with continuously variable adjustment conveniently from the centre console
- Ideal for work involving high demands

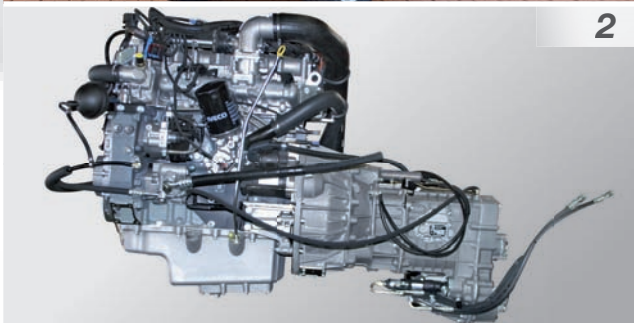

1) Compact and manoeuvrable

With its wheelbase of just 2.93 m, an overall length from 4.86 m (short model) and width of just 1.62 m, the Multicar FUMO moves elegantly through the narrowest of side-streets. The standard power-assisted steering and hydrostatic drive for low working speeds simplify manoeuvring.

2) Powerful and economic

High performance and maximum torque ensure work is completed efficiently. The low-consumption, 3 litre, common rail turbo diesel engine from IVECO produces 107 kW (145 Hp) and a maximum torque of 320 Nm at 1.400 rpm. Compliance with Euro 5 and EEV also enable working in environmental zones.

3) All-terrain vehicle

Equipped with a 4x4 all-wheel drive option and differential lock, ten forward and two reverse gears (4x4 version) incl. crawling gear plus anti-skid tyres, the Multicar FUMO with crew cabin is a real off-roader and likes to be employed, for example, on forest paths, building sites, hilly grounds or in the open country.

Multicar FUMO C
with crew cabin,
irrigation system and a
1.800 litre water tank.

The Multicar FUMO with crew cabin: A team-mate you can always rely on

Wide range of deployment

Whether in the municipality, gardening and landscaping, building trade or waste disposal: The Multicar FUMO is ideal for use everywhere where compact, implement carrier services are required.

All-year-round deployment possibilities

- Transportation work with three-way tipper or skip loader functions, also in combination with loading crane or grab
- Waste disposal tasks in pedestrian precincts, parks and areas with narrow access roads
- Maintenance and repair work using aerial working platforms
- Cleaning drains with gully sluicing or vacuum-sluicing equipment and cleaning gullies with drain cover lifter

Seasonal deployment possibilities

- Winter services with snow plough or snow brushes, gritting device
- Sweeping work with front attachment device and vacuum sweeper machines
- Cleaning using water pressure (e.g. front washing bar) or hand-operated cleaning and spraying devices
- Mowers with mowing bars, rotary mowers, flail mowers, mower extension arms and mower-vacuum combinations
- Tree and forest maintenance, cutting trees from aerial working platform up to 11 m, shredding and transporting waste foliage





Limitlessly functional

From municipality to orcharding: The comprehensive range of implements and accessories has made the Multicar FUMO with crew cabin more versatile than ever. Its modular concept means that its use in future is also guaranteed through new implements and accessories.

Our accessories make the Multicar FUMO with crew cabin even better

Special equipment

Use Multicar original accessories to adapt the Multicar FUMO with crew cabin even more closely to your specific requirements. Every extra is especially aligned to your Multicar FUMO. Therefore, you can be sure that everything fits and works – whether practical extensions for increasing the work output or providing convenient, specific solutions for you and your employees.



4x4 all-wheel drive

for increased traction on and off road



Differential lock

for more safety in open terrain and at work



Air-con unit

ensures concentrated work at high temperatures



Front windscreen heater

for excellent vision in cold weather



Auxiliary heater with engine preheating

warms up quicker in winter



Sprung comfort seat

for even more relaxed working



Electrical front windows

for convenient ventilation

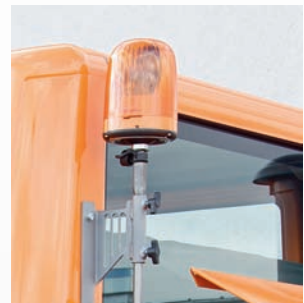

Telescopic flashing beacon

on a stand (either one or two)

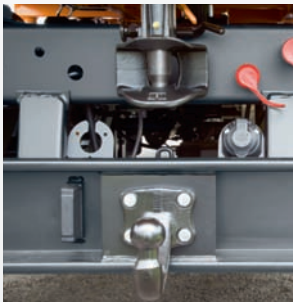

Automatic shackle type coupling

and ball-type trailer hitch



Working lights

for visibility and safety



Lighting bar

can be seen from afar



On-demand engine brake

Increases active safety

Tyres

In series production, the Multicar FUMO with crew cabin is fitted with the proven 225/75 R 16 C summer tyres.

To match the wide range of your individual working tasks, there is a wide range of other tyres available for selection:

- 225/75 R 16 C summer tyres (series production)
- 225/75 R 16 C all-season tyres (M&S)
- 225/75 R 16 C winter tires (M&S)
- 285/65 R 16 C all-season tyres (M&S)
- 315/55 R 16 off-road tyres (M&S)
- 325/60 R 15 wide base tyres, min. ground pressure



A combination of quality and long working life

Choosing a Multicar means choosing top-quality aligned with sustainability. A highly modern cataphoretic dip painting system, the use of environmentally friendly, water

base paints, sealing of overlaps and additional underbody coatings ensure vehicles have a high quality surface coating, first class anticorrosive and a long service life.



Quick-change device SWV 500

with integrated raising feature for easy, one-man operation when changing devices

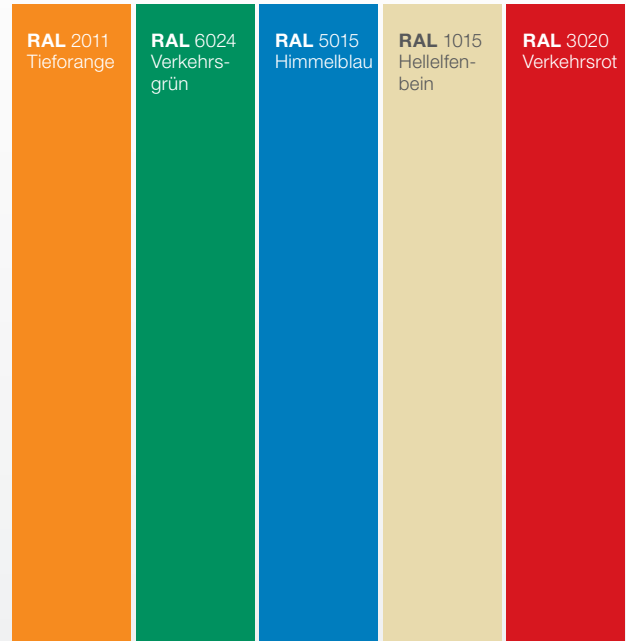

RAL colours

on request, we can paint your Multicar FUMO with crew cabin in the RAL colour of your choice.

Technical data

	Multicar FUMO T with crew cabin	Multicar FUMO C with crew cabin
Engine and transmission		
Engine	IVECO F 1 C turbo diesel	
Capacity	2,998 cm ³	
Power output	107 kW (145 Hp) at 3,500 rpm	
Max. torque	320 Nm at 1,400 rpm	
Pollutant emissions	Compliant with Euro 5 and EEV with particle filter in closed system	
Transmission	5 forward gears and 1 reverse gear; with all-wheel drive incl. crawling gear: 10 forward and 2 reverse gears	
Handling characteristics		
Speed range Cl. N2	0–90 km/h	
Speed range Cl. N1	0–110 km/h	
Crawling gear 1	0.6–16.5 km/h	
Chassis	Twistable profile frame of steel	
Wheelbase	2,930 mm	
Axles/Suspension, front	Independent suspension with helical springs	
Axles/Suspension, rear	Rigid axle with progressive leaf spring	
Tyres	225/75 R 16 C (series production), other tyres available as special optional equipment	
Driver's cab	Tilting space-frame cab	
Drive and control unit		
Drive	4x2 drive, selectable 4x4-all-wheel drive option	selectable 4x4 all-wheel drive (series production)
Clutch	Hydraulically actuated, asbestos-free	
Steering	Power-assisted steering (hydro steering)	
Tank volume	80 litres	
Brakes	4-wheel disc brakes (ventilated disc) with 4-channel ABS	

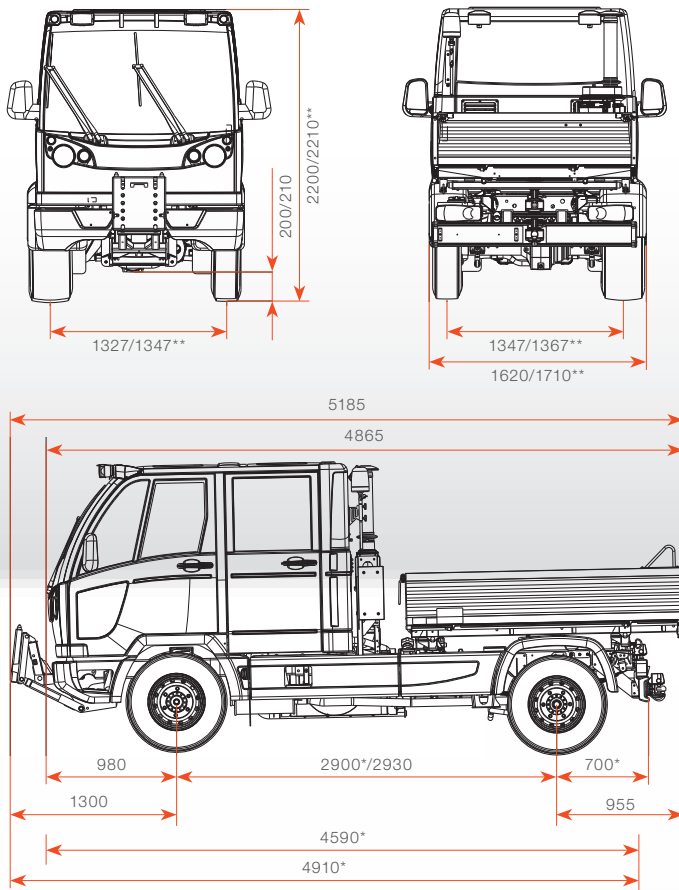

* valid for the chassis (without mounted implements)

** valid for the tyres LT 325/60 R 15, 315/55 R 16, 285/65 R 16 C

You can count on a Multicar at all times

We provide expert advice prior to purchase and excellent financing and leasing options. After purchasing the high quality product, we provide experienced after-sales service 24 hours a day and are close by!

	Multicar FUMO T with crew cabin	Multicar FUMO C with crew cabin
Load values		
Max. permissible weight	Up to 5.6 t	
Permissible front axle load	2.4 t	
Permissible rear axle load	Up to 3.67 t	
Payload with 4x2 drive*	Up to 2.9 t*	
Payload with 4x4 drive*	Up to 2.75 t*	Equipment and model dependent
Permissible trailer weight	3.5 t (brake-assisted), 0.75 t (non break-assisted)	
Gross combination weight rating	7.5 t	
Hydraulics		
Electrical tipping hydraulics	Max. 5 l/min, Max. working pressure 150 bar	
3-circuit universal hydraulics	-	Max. 80 l/min, Max. working pressure 200 bar
3-circuit high pressure comfort hydraulics	-	Max. 80 l/min, Max. working pressure 300/200 bar

*Additional equipment reduces payload

Hako

Clean ahead



Hako: environmental-friendly right from the start

It is our legacy to leave behind a clean planet. That is why resources-, environmental- and climate protection characterize each and every process at Hako which has been certified by independent institutions. Learn more about our on-going commitment at www.hako.com

Close to you wherever you are

Our efficient close-knit sales & service network guarantees close proximity and rapid help.

Cleanliness combined with safety

Our machines meet the highest standards. Reliable quality "Made by Hako".

Buying, leasing, renting

We offer you a number of individual and attractive financing & procurement options.

We are available 24/7

Hako's spare part express- and on-call service guarantees best possible availability.

**Auto SAS**[®]
MANIPULAČNÍ TECHNIKA
Gabelstapler und Multicar - Fahrzeugen
Forklift stackers & Multicar vehicles
Auto SAS s.r.o., Rychnovská 577, CZ - 517 01 Solnice
Tel. +420 494 590 100, fax: +420 494 590 104
www.autosas.cz



DIN EN ISO 9001
DIN EN ISO 14001

Hako GmbH
Head office
Hamburger Str. 209-239
23843 Bad Oldesloe
Tel. +49(0)4531-806 0
info@hako.com
www.hako.com