

## Electric towing tractor 20 - 25 ton

**TRACTO**

R-series

2TE



# Electric towing tractor 20 - 25 ton

Truck specifications					2TE15	2TE18
Identification	1.1	Manufacturer			Toyota	Toyota
	1.2	Model			2TE15	2TE18
	1.3	Drive			Electric	Electric
	1.4	Operator type			Rider seated	Rider seated
	1.5	Load capacity/rated load	Q	kg	20000	25000
	1.7	Rated drawbar pull	F	N	3920	4900
	1.9	Wheelbase	y	mm	1600	1600
Weight	2.1	Service weight		kg	3050 <sup>1)</sup>	3400 <sup>1)</sup>
	2.2	Axle load, with load, front/rear		kg		
	2.3	Axle load, without load, front/rear		kg	1470/1580	1430/1970
Tyres	3.1	Tyre - pneumatic (P), pneumatic shaped cushion (SE), solid rubber (R)			P	P
	3.2	Tyre size, front			165R13-8PR (LT)	175R13-8PR (LT)
	3.3	Tyre size, rear			7.00-12-12PR (I)	28x8-15-12PR (I)
	3.5	Wheels, number front/rear (x = driven wheels)			2/2x	2/2x
	3.6	Track width, front	b <sub>10</sub>	mm	1175	1175
	3.7	Track width, rear	b <sub>11</sub>	mm	1110	1110
	Dimensions	4.8	Seat height/stand height	h <sub>7</sub>	mm	860
4.12		Coupling height	h <sub>10</sub>	mm	450	450
4.17		Overhang	l <sub>5</sub>	mm	1065	1065
4.19		Overall length	l <sub>1</sub>	mm	3615	3615
4.21		Overall width	b <sub>1</sub>	mm	1420	1420
4.32		Ground clearance, centre of wheelbase	m <sub>2</sub>	mm	150	150
4.35		Turning radius	W <sub>a</sub>	mm	3295	3295
Performance data	5.1	Travel speed, with/without load		km/h	11,0 <sup>2)</sup> /25,0	14,5 <sup>3)</sup> /28,0
	5.6	Max. drawbar pull		N	14600	17640
	5.7	Gradeability		%	26	32
	5.10	Service brake			Hydraulic	Hydraulic
Electric motor	6.1	Drive motor rating S2 60 min		kW	11,8	16,6
	6.4	Battery voltage, nominal capacity K <sub>s</sub>		V/Ah	80/445	80/445
	6.5	Battery weight		kg	1150	1150
Others	8.1	Type of drive control			Transistor inverter	Transistor inverter
	8.4	Sound level at driver's ear according to EN 12053		dB(A)	77 <sup>4)</sup>	85 <sup>4)</sup>

<sup>1)</sup> With battery weight = 1150 kg

<sup>2)</sup> With 14 ton load (travel speed with 8 ton load = 14,5 km/h)

<sup>3)</sup> With 14 ton load (travel speed with 8 ton load = 20,0 km/h)

<sup>4)</sup> With sunshade with front and top glass.

Performance data and dimensions are nominal and subject to tolerances.

Specifications are subject to change without notice.

Please obtain the latest specifications before contracting products.

# Towed weight

# TRACTO

Model		2TE15	2TE18	2TE15	2TE18	2TE15	2TE18	2TE15	2TE18
		Level start				Start on grade			
Surface condition (Dry even concrete)		3-minute rating		60-minute rating		3-minute rating		60-minute rating	
Start, level road	ton	20,0	25,0	20,0	25,0	—	—	—	—
Start, 1 degree	ton	20,0	25,0	9,2	11,7	17,1	20,6	9,2	11,7
Start, 2 degrees	ton	20,0	25,0	5,3	6,8	13,3	16,1	5,3	6,8
Start, 3 degrees	ton	18,5	22,3	3,3	4,3	10,8	13,1	3,5	4,3
Start, 4 degrees	ton	14,3	17,3	2,0	2,8	8,9	10,8	2,0	2,8
Start, 5 degrees	ton	11,5	13,9	1,2	1,7	7,5	9,1	1,2	1,7
Start, 6 degrees	ton	9,4	11,4	0,6	1,0	6,4	7,8	0,6	1,0
Start, 7 degrees	ton	7,9	9,6	0,1	0,4	5,5	6,7	0,1	0,4
Start, 8 degrees	ton	6,7	8,2	—	—	4,7	5,8	—	—
Start, 9 degrees	ton	5,7	7,0	—	—	4,1	5,1	—	—
Start, 10 degrees	ton	4,9	6,1	—	—	3,6	4,4	—	—

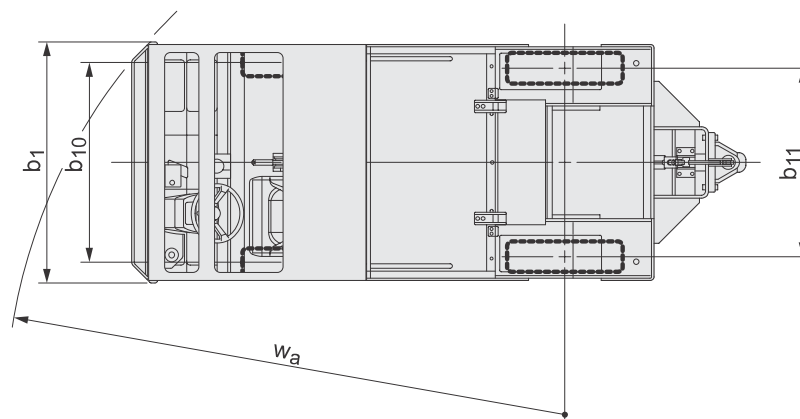
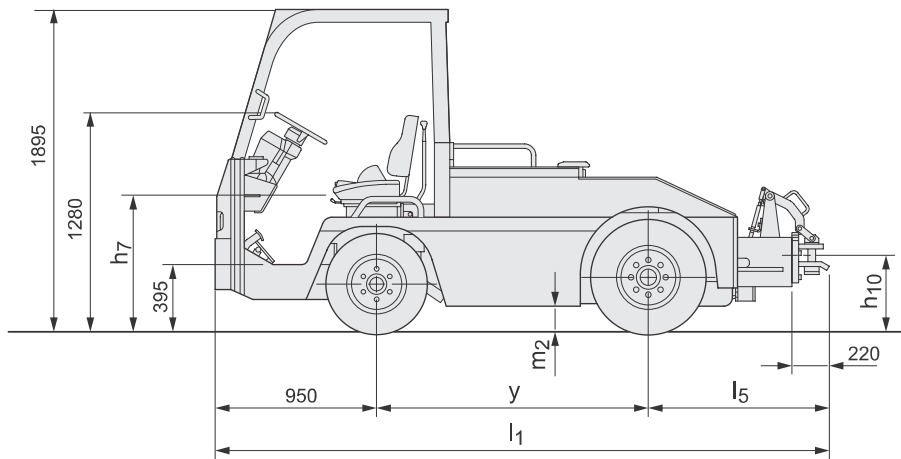

## Standard equipments:

- Toyota OPS (Operator Presence Sensing)
- Pneumatic tyres
- Full hydraulic power steering
- Pin type single stage drawbar
- Headlights
- Digital multifunction display
- Adjustable steering column
- Emergency lever
- Cabins available as option

**AUTOSAS®**

komunální a manipulační technika

Auto SAS s.r.o.  
IČ: 49679139, DIČ: CZ49679139  
517 01 Solnice, Rychnovská 577

[WWW.AUTOSAS.CZ](http://WWW.AUTOSAS.CZ)

TP-Technical Publications, Sweden — 745540-040, version 2, 1202

**TOYOTA**

**MATERIAL HANDLING**