

Cleaning Technology · Municipal Technology

**Hako**  
Clean ahead



## **Multicar M27**

### **Functional and Economic**

*Transporter and implement carrier – the innovative result of a long tradition*





**Regardless of what your everyday work requires: The Multicar M27 is perfectly equipped to complete the jobs at hand**

A Multicar stands for functionality and efficiency. The Multicar M27 brings a new component with it: Comfort. This is provided by the optimised interior of the space-frame cab and its excellent car-like handling characteristics with power-assisted steering and a top speed of 90 km/h. The Multicar M27 is the ideal partner to complete all your tasks – tailor-made with two different wheelbases, 4x2 or 4x4 drive and various hydraulic systems!





The Multicar M27 C  
with three-way tipper

Compact and manoeuvrable:  
Only 1.62 m wide  
and just 2.2 m high

Payload up to 2.9 t – grits  
longer, sweeps further thus  
sparing a lot of driving

Fast and comfortable:  
Car-like handling with 5 gears,  
power-assisted steering and  
speeds 90 km/h

Convenient and safe, and as multifunctional as ever

# Multicar M27 Maximum efficiency is guaranteed

## High performance and versatile

Powerful implement carrier and high transporting performance result in an attractive price-performance ratio: This is the formula for success of the Multicar M27. A real Multicar which includes all of the strengths of its predecessors and is provided with innovative solutions to simplify completion all of today's workloads in municipalities, gardening and landscaping, building industry and waste disposal.

## Ergonomic and safe

- The ergonomic space-frame cab provides freedom of movement and optimum visibility of the equipment and surrounding area
- Precise control of the equipment directly from the cab using the joystick
- Simple change to crawling gear when delicate manoeuvring is required

## Modular and economic

- The modular vehicle concept ensures it can be used for years to come, optional equipment can be replaced or retrofit later simply and easily
- The high quality of all the assemblies, long periods between servicing and simple diagnosis options guarantee a long service life and low consequential costs

## Quality made in Germany

Multicar has been developed and produced in Germany for more than 50 years.



Compact and manoeuvrable with a width of 1.62 m and turning radius of just 5.4 m



Robust attachment points at the front, top and rear, quick-change system at the front and equipped with ball coupling system for economic one-man operation







Robust and strong  
with up to 2.9 t  
payload max. and  
7.5 t gross  
combination  
weight rating



High performance and economic:  
Low-noise, 2-litre turbodiesel engine  
from VW producing 75 kW (102 Hp),  
complies with EURO 5 and EEV  
standard for use in all low emission zones



Safe and stays on track  
thanks to the independent  
suspension at the front,  
ventilated disc brakes  
and 4-channel ABS on  
all four wheels



Variable hydraulic availability  
of the tipper with 1-circuit  
hydraulics to mobile 2-circuit  
and 3-circuit hydraulics for  
universal implement carriers

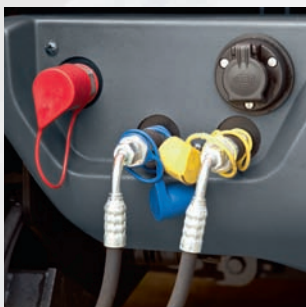





**1) 5-gear transmission**

precise and clean gear changing, it handles like a car

**2) Selectable 4x4 wheel drive and crawling gear**

as well as ten forward and two reverse gears for optimum traction

**3) Joystick**

for easy operation of the most important functions

**4) Light, smooth power-assisted steering**

hydraulic steering enables easy, precise manoeuvring

**5) Air-con unit**

aids concentration while working in pleasant conditions, even on hot summer days

**6) Comfort seat for driver and front passenger**

ergonomic, adjustable longitudinally and vertically and adjustable backrest







Ergonomic, neat and tidy:  
The comfort cab

## *Ergonomic, functional and clear: Your workplace in the Multicar M27*

The optimised interior of the comfort cab for the Multicar M27 provides enough room for you to complete your tasks easily and quickly in a sound-insulated environment. The driver's cab has been completely redesigned according to ergonomic aspects. First class functionality with close attention to details simplifies work: the low extension of the windows, for example. They provide a perfect view of the working area and working apparatus. The quick-change system installed at the front is designed to enable uncomplicated, one-man operation. Full work convenience is guaranteed!



Compact, high performance and versatile

## Three convincing arguments for the Multicar M27



Different Multicar M27 basic models for every main area of application can be equipped and upgraded individually to meet your very own requirements.

### **Multicar M27 T**

The powerful transporter with high transport capacity. Available as a three-way tipper with short or long wheelbase and alternatively with 4x2 or 4x4 drive.

#### **The ideal vehicle for:**

- transporting on roads and in open terrain
- loading debris and package freight on the three-way tipper
- increasing transport capacity by attaching a trailer (permissible trailer weight of 3.5 t)

### **Multicar M27 B**

The robust transport vehicle with proven 1-circuit hydraulics (up to 45 l/min and 200 bar), perfectly suited for driving stationary operated attachments and devices.

#### **The ideal vehicle for:**

- transport with a three-way tipper, skip loader or dumper
- refuse compactor attachment
- aerial work platform
- loading crane
- gully cleaner

### **Multicar M27 C**

The 4x4 professional implement carrier with 2 or 3-circuit hydraulics and summation circuit. Can drive several devices simultaneously and independently of each other.

#### **The ideal vehicle for:**

- winter service (gritter and snow plough or snow sweeper)
- mowing implements and weed brushes
- foliage and waste vacuum
- road sweeper
- sluicing equipment
- drain sluicing





**1) Compact**

With a width of just 1.62 m and a turning radius of a mere 5.4 m, the Multicar M27 is fast and manoeuvrable in confined pedestrian precincts and parks.

**2) High performance**

75 kW (102 Hp) enable the Multicar M27 to accelerate fast 90 km/h – with a payload up to 2.9 t and permissible trailer weight up to 3.5 t!

**3) Versatile**

The three attachment points and various hydraulics mean that the Multicar M27 provides the best conditions for the widest range of implements and attachments.

**Be prepared for next winter**

The light winter service option package is designed to operate both a snow plough and an electric spreader on the Multicar M27 T 4x4 – the clever, low-priced alternative to fully equipped implement carriers.



The Multicar M27 B  
deployed as a  
compact skip loader

## *Hundreds of tasks, one solution: the multifunctional Multicar M27*

### **High level of flexibility**

The wide range of implements available for the max. three attachment points render the Multicar M27 a versatile all-rounder. It can be re-equipped quickly for the next job in just a few steps enabling it to be used all-year-round and round-the-clock on roads, in pedestrian precincts or in parks.

### **Wide range of deployment**

Whether for municipalities or road maintenance, gardening and landscaping, service or building industry: The Multicar M27 is ideal for use everywhere where compact implement carrier work is necessary.

### **Excellent efficiency**

Deploying the Multicar M27 can pay you back in many ways. The high quality materials used, the first class workmanship and excellent corrosion resistance ensure a long service life. The high-performance turbo diesel engine has low fuel consumption, thus reducing operating costs. The service-friendly design means that maintenance work can be completed quickly and economically.







### **Limitlessly functional**

From municipality to orcharding: The comprehensive range of implements and accessories has made the Multicar M27 more versatile than ever. Its modular concept means that its use in future is also guaranteed through new implements and accessories.



Our accessories make the Multicar M27 even better

## Special equipment

Use Multicar original accessories to adapt the Multicar M27 even more closely to your specific requirements. Every extra is especially aligned to your Multicar M27. Therefore, you can be sure that everything fits and works – whether practical extensions for increasing the work output or providing convenient, specific solutions for you and your employees.



### 4x4 all-wheel drive

for increased traction on roads and open terrain



### Differential lock

for even more safety on open terrain

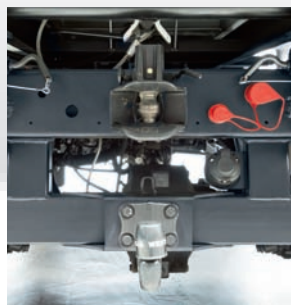

### Rear hydraulics

for connecting implements at the rear



### CD radio with MP3 function and USB-Interface

UKW, RDS, phone muting



### Air-con unit

ensures concentrated work at high temperatures



### Front windscreen heater

for excellent vision in cold weather



### Auxiliary heater with engine preheating

warms up quicker in winter



### Sprung comfort seat

for even more relaxed working



### Electrical front windows

for convenient ventilation



### Quick-change system

for quick conversion

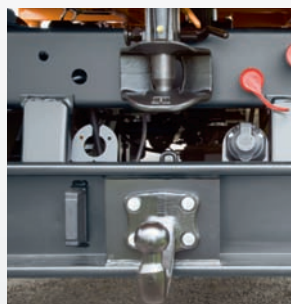

### Automatic shackle type coupling

and ball-type trailer hitch



### Working lights and flashing beacon

for visibility and safety



## Tyres

In series production, the Multicar M27 is fitted with the proven 225/75 R 16 C summer tyres. To match the wide range of your individual working tasks, there is a wide range of other tyres available for selection:

- 225/75 R 16 C summer tyres (series production)
- 225/75 R 16 C all-season tyres (M&S)
- 225/75 R 16 C winter tires (M&S)
- 285/65 R 16 C all-season tyres (M&S)
- 315/55 R 16 off-road tyres (M&S)
- 325/60 R 15 wide base tyres, min. ground pressure



## A combination of quality and long working life

Choosing a Multicar means choosing top-quality aligned with sustainability. A highly modern cataphoretic dip painting system, the use of environmentally friendly, water

base paints, sealing of overlaps and additional underbody coatings ensure vehicles have a high quality surface coating, first class anticorrosive and a long service life.



## Quick-change device SWV 500

with integrated raising feature for easy, one-man operation when changing devices



## RAL colours

on request, we can paint your Multicar M27 in the RAL colour of your choice.

## Technical data

	Multicar M27 T	Multicar M27 B	Multicar M27 C
<b>Engine and transmission</b>			
Engine	High-performance, 2-litre VW turbo diesel		
Power output	75 kW (102 Hp) at 3,500 rpm		
Max. torque	250 Nm at 1,600 to 2,600 rpm		
Pollutant emissions	Maintenance-free particle filter in closed system, fulfils Euro 5 and EEV		
Drive	4x2 or 4x4 all-wheel drive with crawling gear		4x4 all-wheel drive with crawling gear (standard)
Transmission	5 forward and 1 reverse gear (4x2); 10 forward and 2 reverse gears with all-wheel drive incl. crawling gear		
<b>Driving and work characteristics</b>			
Speed	0-90 km/h Crawling gear (with 4x4 all-wheel drive) 0.6-16.5 km/h		
Front axle	Independent suspension with helical springs and telescopic shock absorbers		
Rear axle	Rigid axle with progressive leaf springs and telescopic shock absorbers		
Steering	Power-assisted steering (hydro-steering)		
Brakes	4-wheel disc brakes (ventilated disc) with 4-channel ABS		
Tyres	225/75 R 16 C (series production), other tyres available as special optional equipment		
Driver's cab	Tilting space-frame cab		
<b>Load values</b>			
Max. permissible weight	Up to 5.3 t (tyre-dependent)		
Permissible trailer weight	3.5 t (brake-assisted), 0.75 t (non brake-assisted)		
Gross combination weight rating	Up to 7.5 t		
Max. payload	Up to 2.9 t (equipment-dependent)		
<b>Dimensions</b>			
H/W/D (short/long)	2,200 x 1,620 x 4,115 mm or 2,200 x 1,620 x 4,665 mm (without implements and attachments)		
Wheelbase (short/long)	2,450 mm / 2,990 mm		
Loading space Three-way tipper, short	2,050 x 1,495 x 400 mm		
Loading space Three-way tipper, long	2,620 x 1,495 x 400 mm		

We reserve the right to make technical improvements to machines with regard to shape, colour and design without notice. Illustrations could contain optional equipment.



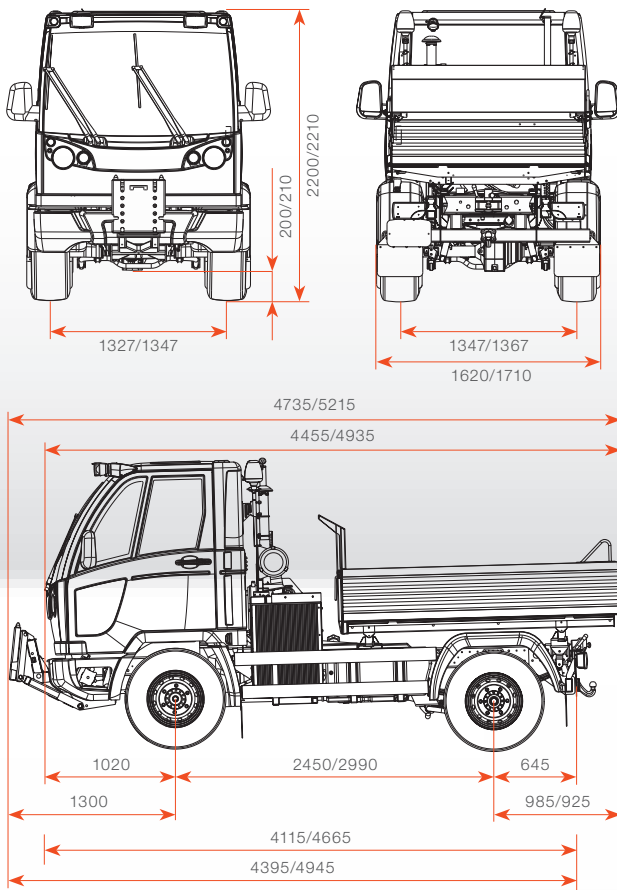

**You can count on a Multicar at all times**

We provide expert advice prior to purchase and excellent financing and leasing options. After purchasing the high quality product, we provide experienced after-sales service 24 hours a day and are close by!

Hydraulics	Multicar M27 T with tipping hydraulics	Multicar M27 B with 1-circuit hydraulics	Multicar M27 C with 2-circuit hydraulics	Multicar M27 C with 3-circuit hydraulics
Tipping hydraulics	Max. 10 l/min; Max. working pressure 160 bar	Max. 10 l/min; Max. working pressure 160 bar	Max. 10 l/min; Max. working pressure 160 bar	Max. 10 l/min; Max. working pressure 160 bar
Stationary 1-circuit hydraulics*	-	Max. 45 l/min; Max. working pressure 200 bar	-	-
Mobile 2-circuit hydraulics*	-	-	Max. 45 l/min; Max. working pressure 200 bar	-
Mobile 3-circuit hydraulics*	-	-	-	Max. 2 x 45 l/min; Max. working pressure 200 bar
Summation circuit	-	-	-	Max. 1 x 90 l/min; Max. working pressure 200 bar

\*including front control functions: raise, lower, floating position and pivot

# Hako

Clean ahead



### **Hako: environmental-friendly right from the start**

It is our legacy to leave behind a clean planet. That is why resources-, environmental- and climate protection characterize each and every process at Hako which has been certified by independent institutions. Learn more about our on-going commitment at [www.hako.com](http://www.hako.com)

### **Close to you wherever you are**

Our efficient close-knit sales & service network guarantees close proximity and rapid help.

### **Cleanliness combined with safety**

Our machines meet the highest standards. Reliable quality "Made by Hako".

### **Buying, leasing, renting**

We offer you a number of individual and attractive financing & procurement options.

### **We are available 24/7**

Hako's spare part express- and on-call service guarantees best possible availability.

 **Auto SAS**<sup>®</sup>  
MANIPULAČNÍ TECHNIKA  
Gabelstapler und Multicar - Fahrzeugen  
Forklift stackers & Multicar vehicles  
Auto SAS s.r.o., Rychnovská 577, CZ - 517 01 Solnice  
Tel. +420 494 590 100, fax: +420 494 590 104  
[www.autosas.cz](http://www.autosas.cz)



**DIN EN ISO 9001**  
**DIN EN ISO 14001**

Hako GmbH  
Head office  
Hamburger Str. 209-239  
23843 Bad Oldesloe  
Tel. +49(0)4531-806 0  
[info@hako.com](mailto:info@hako.com)  
[www.hako.com](http://www.hako.com)