

Engine towing tractor 26 - 33 ton

TRACTO

R-series

2TG/2TD



Engine towing tractor 26.0 ton

Truck specifications				2TG20	02-2TG20	2TD20	02-2TD20	52-2TD20	
Identification	1.1	Manufacturer		Toyota	Toyota	Toyota	Toyota	Toyota	
	1.2	Model		2TG20 ¹⁾	02-2TG20 ²⁾	2TD20 ¹⁾	02-2TD20 ²⁾	52-2TD20 ²⁾	
	1.3	Drive		Gasoline7LPG	Gasoline7LPG	Diesel	Diesel	Diesel	
	1.4	Operator type		Rider seated			Rider seated		
	1.5	Load capacity/rated load	Q	kg	26000 ³⁾	26000 ³⁾	26000 ³⁾	26000 ³⁾	26000 ³⁾
	1.7	Rated drawbar pull	F	N					
	1.9	Wheelbase	y	mm	1600	1600	1600	1600	1710
Weight	2.1	Service weight		kg	3130	3150	3170	3190	3290
	2.2	Axle load, with load, front/rear		kg					
	2.3	Axle load, without load, front/rear		kg	880/2250	890/2260	920/2250	930/2260	1010/2280
Tyres	3.1	Tyre - pneumatic (P), pneumatic shaped cushion (SE)		P	P	P	P	P	
	3.2	Tyre size, front		165R13-8PR(LT)			165R13-8PR(LT)		
	3.3	Tyre size, rear		28x8-15-12PR(I)			28x8-15-12PR(I)		
	3.5	Wheels, number front/rear (x=driven wheels)		2/2x	2/2x	2/2x	2/2x	2/2x	
	3.6	Track width, front	b ₁₀	mm	1225	1225	1225	1225	1225
	3.7	Track width, rear	b ₁₁	mm	1190	1190	1190	1190	1190
	Dimensions	4.8	Seat height/stand height	h ₇	mm	1000	1000	1000	1000
4.12		Coupling height	h ₁₀	mm	450	450	450	450	450
4.17		Overhang	l ₅	mm	570	570	570	570	570
4.19		Overall length	l ₁	mm	3020	3020	3020	3020	3130
4.21		Overall width	b ₁	mm	1445	1445	1445	1445	1445
4.32		Ground clearance, centre of wheelbase	m ₂	mm	150	150	150	150	150
4.35		Turning radius	W _a	mm	3050	3050	3050	3050	3200
Performance data	5.1	Travel speed, with/without load		km/h	25 ^{4)/27}	24 ^{4)/26}	25 ^{4)/27}	24 ^{4)/26}	26 ^{4)/30} [26]
	5.6	Max. drawbar pull		N	20500	20500	20500	20500	20500
	5.8	Max. gradeability without load		%	46	46	46	46	46
	5.10	Service brake			Hydraulic	Hydraulic	Hydraulic	Hydraulic	Hydraulic
Motor	7.1	Engine manufacturer/type			Toyota 4Y			Toyota 1DZ-III	
	7.2	Engine power acc. to ISO 1585		kW	39,7	39,7	38,0	38,0	44,0
	7.3	Rated speed		1/min	2400	2400	2400	2400	2300
	7.4	No. of cylinders/displacement		cm ³	4/2237	4/2237	4/2486	4/2486	4/3469

¹⁾ Manual transmission

²⁾ Automatic transmission

³⁾ Load capacity with one trailer.

Load capacity with a train of two or more trailers = 39000 kg

⁴⁾ With 10 ton load

[] For low-gear specification model, without load

Performance data and dimensions are nominal and subject to tolerances.

Specifications are subject to change without notice.

Please obtain the latest specifications before contracting products.

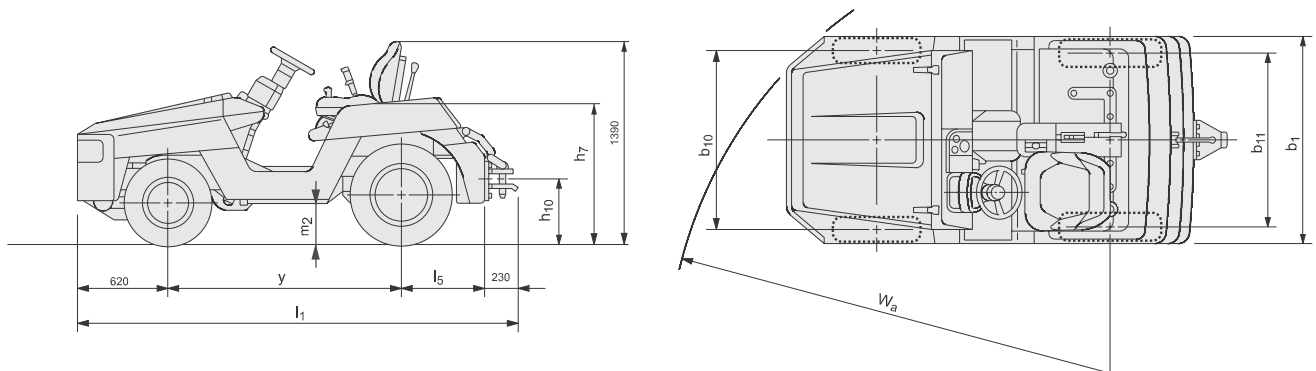

Engine towing tractor 33.0 ton

Truck specifications				2TG25	02-2TG25	2TD25	02-2TD25	52-2TD25		
Identification	1.1	Manufacturer		Toyota	Toyota	Toyota	Toyota	Toyota		
	1.2	Model		2TG25 ¹⁾	02-2TG25 ²⁾	2TD25 ¹⁾	02-2TD25 ²⁾	52-2TD25 ²⁾		
	1.3	Drive		Gasoline/LPG	Gasoline/LPG	Diesel	Diesel	Diesel		
	1.4	Operator type		Rider seated	Rider seated	Rider seated	Rider seated	Rider seated		
	1.5	Load capacity/rated load	Q	kg	33000 ³⁾	33000 ³⁾	33000 ³⁾	33000 ³⁾	33000 ³⁾	
	1.7	Rated drawbar pull	F	N						
	1.9	Wheelbase	y	mm	1600	1600	1600	1600	1710	
Weight	2.1	Service weight		kg	3840	3860	3880	3900	4000	
	2.2	Axle load, with load, front/rear		kg						
	2.3	Axle load, without load, front/rear		kg	870/2970	880/2980	910/2970	920/2980	1000/3000	
Tyres	3.1	Tyre - pneumatic (P), pneumatic shaped cushion (SE)			P	P	P	P	P	
	3.2	Tyre size, front			165R13-8PR(LT)			165R13-8PR(LT)		
	3.3	Tyre size, rear			28x8-15-12PR(I)			28x8-15-12PR(I)		
	3.5	Wheels, number front/rear (x=driven wheels)			2/2x	2/2x	2/2x	2/2x	2/2x	
	3.6	Track width, front	b ₁₀	mm	1225	1225	1225	1225	1225	
	3.7	Track width, rear	b ₁₁	mm	1190	1190	1190	1190	1190	
	Dimensions	4.8	Seat height/stand height	h ₇	mm	1000	1000	1000	1000	1000
4.12		Coupling height	h ₁₀	mm	450	450	450	450	450	
4.17		Overhang	l ₅	mm	570	570	570	570	570	
4.19		Overall length	l ₁	mm	3020	3020	3020	3020	3130	
4.21		Overall width	b ₁	mm	1445	1445	1445	1445	1445	
4.32		Ground clearance, centre of wheelbase	m ₂	mm	150	150	150	150	150	
4.35		Turning radius	W ₈	mm	3050	3050	3050	3050	3200	
Performance data	5.1	Travel speed, with/without load		km/h	25 ^{4)/27}	24 ^{4)/26}	25 ^{4)/27}	24 ^{4)/26}	26 ^{4)/30 [26]}	
	5.6	Max. drawbar pull		N	24500	24500	24500	24500	24500	
	5.8	Max. gradeability without load		%	46	46	46	46	46	
	5.10	Service brake			Hydraulic	Hydraulic	Hydraulic	Hydraulic	Hydraulic	
Motor	7.1	Engine manufacturer/type			Toyota 4Y			Toyota 1DZ-III		Toyota 3Z
	7.2	Engine power acc. to ISO 1585		kW	39,7	39,7	38,0	38,0	44,0	
	7.3	Rated speed		1/min	2400	2400	2400	2400	2300	
	7.4	No. of cylinders/displacement		cm ³	4/2237	4/2237	4/2486	4/2486	4/3469	

¹⁾ Manual transmission

²⁾ Automatic transmission

³⁾ Load capacity with one trailer.

Load capacity with a train of two or more trailers = 49000 kg

⁴⁾ With 10 ton load

[] For low-gear specification model, without load

Towed weight

Model		2TG20	2TD20	52-2TD20	2TG20	2TD20	52-2TD20	2TG25	2TD25	52-2TD25	2TG25	2TD25	52-2TD25
Surface condition (Dry even concrete)		Level start, with one trailer			Start on grade, with one trailer			Level start, with one trailer			Start on grade, with one trailer		
Start, level road	ton	26,0 ¹⁾	26,0 ¹⁾	26,0 ¹⁾	—	—	—	33,0 ¹⁾	33,0 ¹⁾	33,0 ¹⁾	—	—	—
Start, 1 degree	ton	26,0 ¹⁾	26,0 ¹⁾	26,0 ¹⁾	19,0	19,0	19,0	33,0 ¹⁾	33,0 ¹⁾	33,0 ¹⁾	24,0	24,0	24,0
Start, 2 degrees	ton	26,0	26,0	26,0	15,0	15,0	15,0	33,0	33,0	33,0	19,0	19,0	19,0
Start, 3 degrees	ton	23,0	23,0	23,0	13,0	13,0	13,0	29,0	29,0	29,0	16,0	16,0	16,0
Start, 4 degrees	ton	18,0	18,0	18,0	11,0	11,0	11,0	23,0	23,0	23,0	14,0	14,0	14,0
Start, 5 degrees	ton	15,0	15,0	15,0	9,5	9,5	9,5	19,0	19,0	19,0	12,0	12,0	12,0
Start, 6 degrees	ton	12,0	12,0	12,0	8,2	8,2	8,2	16,0	16,0	16,0	10,0	10,0	10,0
Start, 7 degrees	ton	10,0	10,0	10,0	7,2	7,2	7,2	13,0	13,0	13,0	9,3	9,3	9,3
Start, 8 degrees	ton	9,3	9,3	9,3	6,4	6,4	6,4	11,0	11,0	11,0	8,2	8,2	8,2
Start, 9 degrees	ton	8,1	8,1	8,1	5,6	5,6	5,6	10,0	10,0	10,0	7,3	7,3	7,3
Start, 10 degrees	ton	7,1	7,1	7,1	5,0	5,0	5,0	9,1	9,1	9,1	6,5	6,5	6,5

¹⁾ Towed weight can be increased by 50% when pulling two or more trailers.

Performance data and dimensions are nominal and subject to tolerances.

Specifications are subject to change without notice.

Please obtain the latest specifications before contracting products.

Standard equipment:

- Toyota OPS (Operator Presence Sensing)
- Pneumatic tyres
- Power steering
- 7" cyclone air cleaner
- Pin type single stage drawbar
- Headlights
- Rear combination lights
- Integrated monitoring center
- Tilt steering column

AUTOSAS®
komunální a manipulační technika
Auto SAS s.r.o.
IČ: 49679139, DIČ: CZ49679139
517 01 Solnice, Rychnovská 577
WWW.AUTOSAS.CZ

TP-Technical Publications, Sweden — 745541-040, version 4, 1504

TOYOTA

MATERIAL HANDLING